

Chamker®

air



AIR FILTER

MODEL NO: CAT159 & CAT169

PART NO: 3120173 & 3120183

INSTALLATION & MAINTENANCE INSTRUCTIONS

ORIGINAL INSTRUCTIONS

GC0217

INTRODUCTION

Thank you for purchasing this CLARKE in-line Air Filter.

The CAT159 is equipped with a manual water drain tap and the CAT169 drains automatically under pressure.

Before attempting to use this product, please read this manual thoroughly and follow the instructions carefully. In doing so you will ensure the safety of yourself and that of others around you, and you can look forward to your purchase giving you long and satisfactory service.

Your air filter has been designed to give long and trouble free service. If, however, having followed the instructions in this booklet carefully, you encounter problems, consult your local CLARKE dealer.

SPECIFICATIONS

Dimensions (D x W x H)	70 x 70 x 173 mm
Weight	0.528 kg
Air Inlet /Outlet Size	1/2" BSP (female)
Max Outlet Pressure	140 psi / 9.7 bar (9.9 kgf/cm ²)
Max Supply Pressure	213 psi /14.7 bar (15 kgf/cm ²)
Max Flow Rate	110 CFM @ 90psi
Filtration	5 um
Bowl Capacity	45 cm ²
Bowl material	Polycarbonate
Ambient/Media Temperature	0-60 deg C

CONTENTS

- 1 x Air Filter Assembly
- 2 x 1/2" BSP to 1/4" BSP adaptor
- 1 x 1/4" male to male connector

GENERAL SAFETY RULES



CAUTION: FAILURE TO FOLLOW THESE PRECAUTIONS COULD RESULT IN PERSONAL INJURY, AND/OR DAMAGE TO PROPERTY.

WORK ENVIRONMENT

1. Keep the work area clean and tidy.
2. Dress appropriately - do not wear loose clothing or jewellery. Tie long hair out of the way.
3. Keep children and visitors away - do not let children handle the tools.
4. Do not operate air tools where there are flammable liquids or gases.

USE OF AIRLINE EQUIPMENT

1. Stay alert and use common sense - do not operate an air tool when you are tired or under the influence of alcohol, drugs or medication.
2. Do not overreach when using air tools - Keep proper footing and balance at all times.
3. Never use oxygen, CO₂, combustible gasses or any type of bottled gas as a source of power for air tools.
4. Do not exceed the maximum pressure for the airline component stated in the specification.
5. Check airline hoses for leaks or worn condition before use and ensure that all connections are secure.
6. Keep the air supply hose away from heat, oil and sharp edges.
7. Avoid damaging the components for example by applying excessive force of any kind.
8. Always maintain any air tool to be used with care. Keep it clean for the best and safest performance.

COMPRESSED AIRLINE REQUIREMENTS



WARNING: COMPRESSED AIR CAN BE DANGEROUS. ENSURE THAT YOU ARE FAMILIAR WITH ALL PRECAUTIONS RELATING TO THE USE OF COMPRESSORS AND A COMPRESSED AIR SUPPLY.

- Use only clean, dry, regulated compressed air as a power source.
- Air compressors must comply with the appropriate European Community Safety Directives.
- A build-up of moisture in the air compressor will accelerate wear and corrosion in the air tool. Ensure any moisture is drained from the compressor daily and the airline filter is kept clean.
- If an unusually long air hose is required, (over 8 metres), the line pressure or the hose inside diameter may need to be increased.
- The air hose must be rated at least 150% of the maximum operating pressure of the air tool.

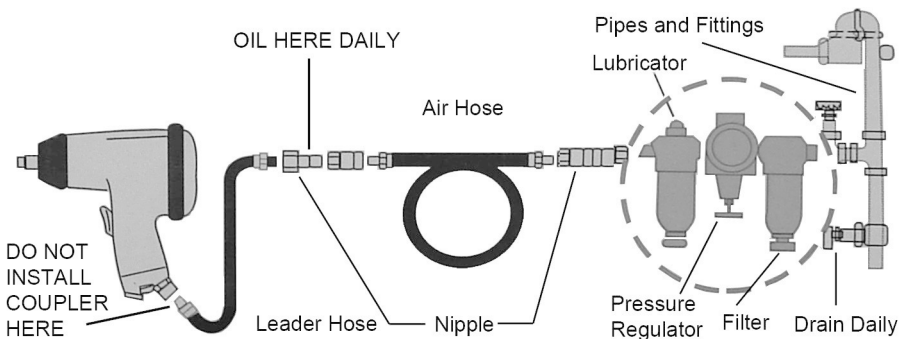

- A typical air line layout is shown above. If an automatic in-line filter & regulator are used, they will keep the tool in good condition, and the lubricator should be regularly checked and topped up with oil. SAE 10 oil should be used, and the lubricator adjusted to approx 2 drops per minute.
- Never exceed the maximum operating pressure for the air tool. Ensure that air pressure does not exceed that stated in the specification for the tool when running. Higher pressures and contaminated air will shorten the life of the air tool due to faster wear and is a possible safety hazard.

INSTALLATION



WARNING: COMPRESSED AIR CAN BE DANGEROUS. ENSURE THAT YOU ARE FAMILIAR WITH ALL PRECAUTIONS RELATING TO THE USE OF AIR COMPRESSORS AND COMPRESSED AIR SYSTEMS.

The filter will usually be connected to rigid airline components to each side.

1. Remove the blanking plugs from each connection port and connect to the supply and delivery hoses.

Note that a pair of 1/4" BSP adaptors are supplied.

- Note the arrow mark on top of the filter body, indicates the direction of air flow.

Use PTFE tape if required, to ensure airtight connections.

2. If required, fit a mounting bracket (available separately) to a suitable support, situated close to the filter.
3. In the case of the CAT169, you may fit a flexible hose to the drain outlet.
4. Your filter is now ready for use.

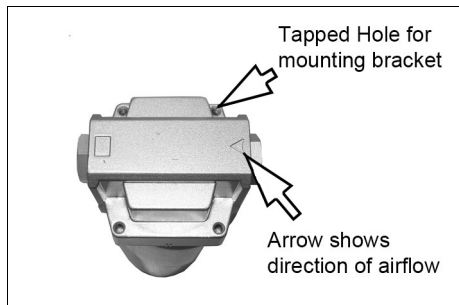
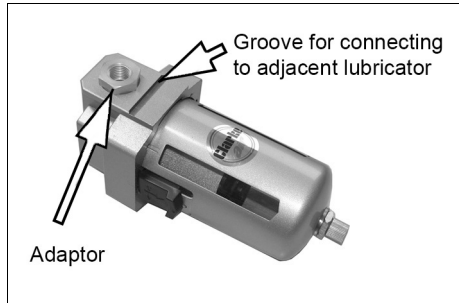

ACCESSORIES

A wide range of accessories is available including filter/regulators, lubricators, high-pressure hoses (5 to 50 metres) etc.

Contact your CLARKE dealer for further information or CLARKE International Service Department.

MAINTENANCE

1. Before using the airline, drain water from the air reservoir at the compressor.
2. Check any supply airline filter for blockage and clean if necessary.
3. Check the condition and the filter bowl and clean out as follows if badly contaminated.
4. Remove the outer bowl cover by pulling the spring loaded catch down and twisting the bowl 45deg, then pulling the bowl from the body (against any frictional resistance from the O-ring).

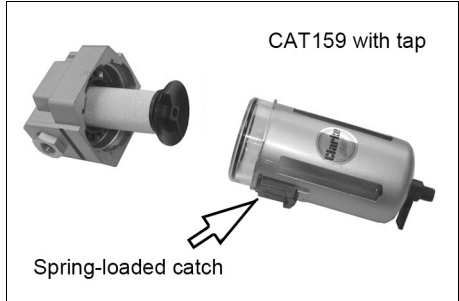

NOTE: In the case of the CAT159 the bowl and bowl cover will remain connected by the drain tap.

5. The clear bowl and filter element can then be washed out before re-assembly.



GUARANTEE

This product is guaranteed against faulty manufacture for a period of 12 months from the date of purchase. Please keep your receipt which will be required as proof of purchase.

This guarantee is invalid if the product is found to have been abused or tampered with in any way, or not used for the purpose for which it was intended.

Faulty goods should be returned to their place of purchase, no product can be returned to us without prior permission.

This guarantee does not effect your statutory rights.

PARTS LIST & DIAGRAM

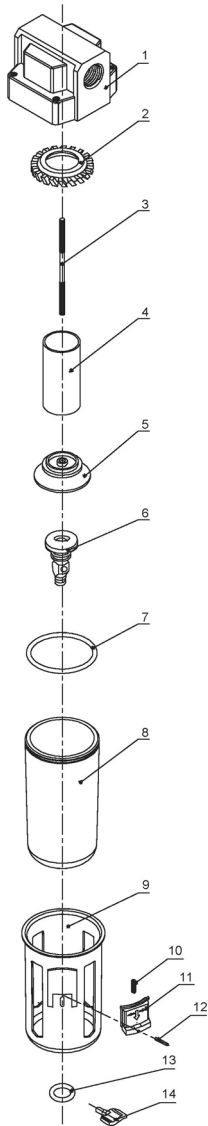

Ref No	Description
1	Main Housing
2	Baffle
3	Screw Arbor
4	Filter Element
5	Baffle Board
6	Drain Valve Seat
7	O-Ring
8	Inner Bowl
9	Outer Bowl
10	Spring
11	Trigger Lock Plate
12	Set Pin
13	O-Ring
14	Manual Drain (CAT159)
	Auto Drain Valve (CAT169)

A SELECTION FROM THE VAST RANGE OF

Clarke®

QUALITY PRODUCTS

AIR COMPRESSORS

From DIY to industrial, Plus air tools, spray guns and accessories.

GENERATORS

Prime duty or emergency standby for business, home and leisure.

POWER WASHERS

Hot and cold, electric and engine driven - we have what you need

WELDERS

Mig, Arc, Tig and Spot. From DIY to auto/industrial.

METALWORKING

Drills, grinders and saws for DIY and professional use.

WOODWORKING

Saws, sanders, lathes, mortisers and dust extraction.

HYDRAULICS

Cranes, body repair kits, transmission jacks for all types of workshop use.

WATER PUMPS

Submersible, electric and engine driven for DIY, agriculture and industry.

POWERTOOLS

Angle grinders, cordless drill sets, saws and sanders.

STARTERS/CHARGERS

All sizes for car and commercial use.



PARTS & SERVICE: 0208 988 7400

E-mail: Parts@clarkeinternational.com or Service@clarkeinternational.com

SALES: UK 01992 565333 or Export 00 44 (0)1992 565335

Clarke® INTERNATIONAL Hemnall Street, Epping, Essex CM16 4LG
www.clarkeinternational.com